



NV 24102



## Handle Legs

for Tubular Handles GN 3330, Stainless Steel,  
Hygienic Design

### SPECIFICATION

- Stainless steel AISI 304 NI
- Matte finish ( $Ra < 0.8 \mu m$ ) MT
- Sealing ring and wiper  
TPU T
- Temperature resistant  $-20 \text{ }^\circ\text{C}$  to  $+110 \text{ }^\circ\text{C}$
- FDA compliant material
- Blue
- Hardness  $95 \pm 5$  Shore A
- Clamping wedge  
Brass
- Grub screw  
Stainless steel

### INFORMATION

Handle legs GN 3331 comply with the DGVU testing principles and are intended for use in hygienic areas. The sealed mounting surface enables fastening without dead spaces. The high quality finish as well as the non-concave geometry prevent adherence of dirt and facilitate cleaning.

The handle legs are designed for use with tubular handles GN 3330 (see page ) to reduce large distances between mounting points or excessive loads on the handle legs. Regardless of the handle application, supports can be used to fix rods and tubes with the corresponding diameter  $d_1$ . The tube or rod is fastened during installation using the integrated clamping wedge.

### ACCESSORY

- Screws GN 1580 (see page )
- Screws GN 1581 (see page )

### TECHNICAL INFORMATION

- Plastic Characteristics (see page A2)
- Stainless Steel Characteristics (see page A26)

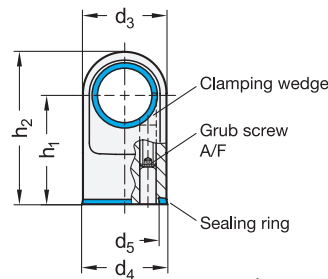
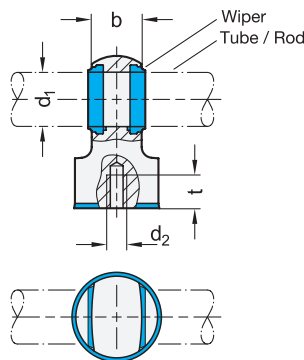

Installation holes

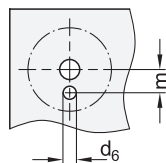

Application examples

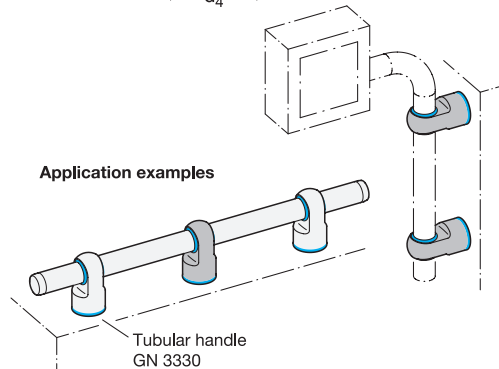

### GN 3331

STAINLESS STEEL

Description	$d_1$ For rod / tube	$h_1$	$b$	$d_2$	$d_3$	$d_4$	$d_5$	$d_6$	$h_2$	A/F	$m$	$t$ min.	$\Delta$
GN 3331-NI-30-60-MT-T	$30 +0.1 / -0.25$	60	27.5	M 10	46	46.6	42	8	84	5	13.5	20	616
GN 3331-NI-40-70-MT-T	$40 +0.15 / -0.3$	70	30	M 12	56	56.8	50	8	99	5	18.5	25	990